



# Saturn Booster

PLEASE READ THESE INSTRUCTIONS CAREFULLY BEFORE USE AND  
KEEP THEM FOR FUTURE REFERENCE

**GB**

The Hozelock Cyprio Saturn Booster is an innovative self-cleaning mechanical prefilter. Designed to operate before any

pump-fed biological filter for fishponds ranging from 5,000 to 30,000 litres, the Saturn Booster will remove up to 75% of pond debris. This reduces filter maintenance and improves the biological performance of your existing filter.

## DESCRIPTION

Dirty water from the pond is pumped into the Saturn Booster and spun around a circular polyester mesh filter. Most particles are trapped by the mesh and then removed by a rotating jet. Dislodged particles fall into a large waste collection area at the bottom, while the cleaned water passes through to your existing filter system.

As it is a sealed unit, waste removal from the Saturn Booster is simply a matter of lifting the flush-away handle for a few seconds every week.

The Saturn Booster is designed for simple retrofitting into an existing installation. The hosesets supplied allow connection to 25mm, 32mm or 40mm hose.

To ensure reliable operation, there are two valves built into the inlet assembly. These are colour coded – blue and red.

The red valve is a filter bypass valve and prevents damage to the Saturn Booster if for whatever reason pressure rises above safe levels. The valve protects the Saturn Booster by redirecting the flow back to pond via the lower hose connection on the inlet assembly.

The blue valve is a self-regulating pressure sensitive relief valve, which ensures optimum operation by controlling the pressure differential across the filter mesh inside the Saturn Booster. Depending on the flow rate and level of debris, the valve can move down during normal operation, indicating that it is regulating the pressure.

## SAFETY AND ELECTRICAL CONNECTIONS

(in accordance with wiring regulations)

From 1st January 2005 installing this product in the garden is classed as 'notifiable' in the revised Building Regulations for England and Wales. The Regulations now require you to tell your local authority building control department that you intend to install this product before installation.

Your local authority will let you know how you can get your installation approved.

- Always disconnect the electricity supply before starting to handle, maintain, repair or install any pond equipment.
- This product is not submersible, and should be sited where it cannot fall into the water or become waterlogged. However, the design is weatherproof, and the Saturn Booster can be safely installed outdoors.
- This product is supplied with 10m of 3 core electric cable for connection to the mains supply. The termination to the mains supply should be permanent, inside a dry, weatherproof enclosure, through a double pole switched fused spur with a minimum contact gap of 3mm – '(disconnector) to BS 3676' – and fitted with a 3 amp fuse.
- **THIS APPLIANCE MUST BE EARTHED AND IT IS ESSENTIAL THAT THE CONNECTIONS ARE MADE USING THE FOLLOWING CODE;**



The **BROWN** lead should be connected to the **LIVE** terminal which may be marked with an 'L' or coloured brown or red. The **BLUE** lead should be connected to the **NEUTRAL** terminal which may be marked with an 'N' or coloured blue or black. The **GREEN/YELLOW** lead should be connected to the **EARTH** terminal which may be marked with an 'E' or coloured green or green/yellow.

- Exposed cable runs should be sensibly positioned and protected if necessary by armoured conduit.
- A 10mA or 30mA Residual Current Circuit Breaker (RCD) MUST be fitted to the mains supply.
- Permanent installations to the mains supply (hard wiring) must comply with the regulations of your local authority. Contact your local authority building control department for advice before you start installation and they will let you know how to get your installation approved.
- If in any doubt about wiring to the mains supply, consult a qualified

electrician or your local authority.

- If the electrical cable is damaged on the outside of the unit it must be replaced by a special cord or electrical assembly available from Hozelock Cyprio or specialist retailer.
- Protect from frost if the unit is not run year round, by draining and removing to a store in a dry, frost protected place.
- When full of water, the Saturn Booster weighs nearly 100kg. **DO NOT** attempt to move when full of water. To drain, pull up the flush handle to empty some of the water, and then gently tilt the Booster until most of the water is emptied.

**IMPORTANT NOTE:** The Booster is a sealed product and can be installed below pond level. If you plan to bury it you will have to remove the lid and siphon or ladle the water out to empty it (for winter storage).

## 1. INSTALLATION

**Important:**

The Saturn Booster can be fitted in a wide variety of installations. However the following conditions must be met:

- Water flow through the Saturn Booster must be between 3000 litres per hour and 8000 litres per hour.
- The Saturn Booster has to be connected to an in-pond pump i.e. it is not suitable for gravity-fed installations.
- Ensure the in-pond pump is raised 200mm (9") above the bottom of the pond. This will prevent any sediment on the pond floor overwhelming your filter, and in the event of a leak outside the pond, prevent your pond from being completely emptied. If the pond has a lot of debris on the bottom, it is always best to remove it with a pond vacuum before installing a new filter.
- The Saturn Booster must be installed directly after the in-pond pump and before both the Filter and Ultra Violet Clarifier (UVC).
- The pump supplying the Saturn Booster must not have a maximum head performance exceeding 6m (9 psi, 0.6 bar).
- The outlet and flush away hoses must not rise more than 1m above their connection to the outlet assembly.

To complete the installation you will need two additional hoses:

1. One of 25mm, 32mm or 40mm diameter

to take the waste from the Saturn Booster to a convenient flower bed or drain (the 'Flush Away Hose')

2. A hose with the same diameter as your existing pond pump hose to connect from the filter bypass valve on the Saturn Booster back to your pond (the 'Bypass' hose).

#### Assembly

Unpack all contents from the box (Fig 1).

The Booster only requires the fitting of the inlet assembly (see Fig 2)

- Gently push the inlet assembly into the lid carefully aligning the two valves (Fig 2B)
- Tighten the two bolts using the Allen Key supplied (Fig 2C)

#### Installation

The Saturn Booster should be sited out of the pond in a position that is easily accessible and where the waste hose can be run to a convenient flowerbed or drain. The Saturn Booster should be connected directly to your in-pond pump hose (i.e. before your Filter [and UVC if fitted]) (Fig 3). The outlet and waste hoses must not be raised more than one metre above the Saturn Booster (Fig 4); otherwise the filter bypass valve will affect the performance of the Saturn Booster.

The Saturn Booster should sit on a smooth and level surface eg. a paving slab.

#### Inlet and Outlet Hoses:

- Cut your existing hose with a hacksaw at the position where the Booster will be installed, noting that the hose length between the Booster and your filter should be no more than 2m (Fig 5).
- If using 32mm or 40mm hose, cut two of the hosetails supplied with a hacksaw to suit (Fig 6) and attach to the top connection on both the inlet assembly and outlet assembly.
- Wrap the adhesive foam strips around the hose and position the jubilee clips over the foam strips to connect the hose from the pond pump to the inlet assembly hosetail (Fig 7A), and the hose to your filter to the outlet assembly hosetail (Fig 7B).

#### Flush-Away Hose:

The flush-away hose can have a diameter of 25mm, 32mm or 40mm and connects to the bottom connection on the outlet assembly using the hosetail and jubilee clip supplied (Fig 8A). Remember that the end of this hose must not be more than one metre higher than the Saturn Booster.

#### Filter Bypass Hose:

The filter bypass hose must be the same diameter as your pond pump hose and connects to the bottom connection on the inlet assembly using the hosetail and jubilee clip supplied (Fig 8B).

#### Turning the Saturn Booster on for the first time

Once you have connected the power cable to your mains electrical supply in accordance with the Safety and Electrical Instructions above you are ready to start.

- Make sure the flush-away handle is pushed fully down to ensure there isn't a leak path out of the flush-away hose.
- Turn on the pond pump. Within a couple of minutes water will start filtering through the Saturn Booster and into your filter system.

! If there isn't any water flowing through

to your filter system after a couple of minutes, double check that the pond pump is working, and that the Saturn Booster's inlet hose is correctly connected to the top connection on the inlet assembly.

- Turn on the Saturn Booster power supply. The Saturn Booster will now backwash the internal mesh filter removing solid waste that will settle in the bottom of the vessel.
- Check that there isn't any water flowing from the flush-away hose and filter bypass hose.

! If water is flowing out of the flush-away hose check that the flush-away handle is pushed right down. If water continues to flow from the hose, raise and lower the flush-away handle a couple of times in case some debris is trapped in the valve.

! If water flows out of the filter bypass hose this is because the pressure in the Saturn Booster is too high. There are three possible causes:

- 1) Your pond pump is delivering too much flow/pressure. Provided you still have reasonable flow to your filter system, this is not a problem, however fitting a valve in the pond pump hose to restrict the flow to the Booster will stop the overpressure valve from operating all the time (Fig 9).
  - 2) The flow of water from the Saturn Booster outlet to the pond is being restricted. Check all hoses between the Saturn Booster and your filter system are clear of obstruction. Check that your filter system is not restricting the flow.
  - 3) The difference in height between the Saturn Booster and Biofilter is too great. If your filter system is, for example, at the top of a waterfall, ideally position the Saturn Booster at the same height.
- Confirm that the flush-away valve is working by lifting the flush-away handle and checking that water flows from the flush-away hose. If the flow of water from the hose is a lot less than that flowing into your filter system, check the flush-away hose for obstructions and also double check that it is not raised more than one metre above the Saturn Booster.

## 2. OPERATION AND MAINTENANCE

### Operation:

#### Flushing out waste

At least once every week the waste should be flushed out. This is done by lifting the flush-away handle (Fig 10). When the flush-away handle is fully-raised, the water flow is redirected to the flush-away hose.

Usually, all of the waste will be flushed out within fifteen seconds. This can be confirmed by looking at the visible portion of the translucent hosetail and waiting for the water flowing through the hosetail to clear.

When complete, lower (Fig 11) to redirect the flow to your filter system. If water continues to flow from the waste hose, raise and lower the flush away handle a couple of times to dislodge any debris that may have become trapped in the valve.

#### Pressure Sensitive Relief Valve (Blue)

Depending on the flow rate and debris, the blue valve can move down during normal operation. This indicates that it is regulating the pressure. If your installation has a high level of debris being pumped from your pond, the blue valve will stay partially open. In this situation, it is recommended that the Booster waste is flushed away daily. During flushing the valve will rise fully, but will fall partially soon after completion. In these conditions although the Saturn Booster will continue to remove high levels of debris, reducing the flow rate can increase performance further. With the improved filtration provided by the Saturn Booster, reducing the flow rate can often lead to improved water clarity and quality as a result of lower flow velocity through the mechanical filter, increased dwell time for biological action, and increased exposure to the UVC (where fitted). Fitting a valve in the pond pump hose (fig 9) is a simple way to adjust the flow.

Another cause for high debris levels is if the in-pond pump is placed on the bottom of a dirty pond (see point 3 in 'Installation').

If the Booster has not been desludged for some while, and the blue valve has moved down, raise and lower the flush-away handle 5 times, leaving it raised for just a couple of seconds each time before flushing out all the waste for 15 seconds. This will ensure that any debris that has built up will be dislodged and flushed out.

#### Blanket weed treatment

If you have treated your blanket weed with a proprietary blanket weed treatment, this causes the blanket weed to fragment which can then enter the Booster and block the mesh filter. To avoid this, remove the Booster from your filter system and reconnect your pond pump hose directly to your filter. The Booster can be re-connected once the suspended blanket weed has been removed from your pond. This can take between 4-6 weeks.

#### Winter Storage

If the unit is not run all year round, protect it from frost in the winter by draining and storing the unit in a dry place.

To drain, pull up the flush handle to empty some of the water, and then gently tilt the Saturn Booster until most of the water is emptied.

#### Maintenance

The Booster is designed for continuous operation and should not require any maintenance.

In the unlikely event that you experience a problem, please use the 'check-list' below to identify the cause.

### ATTENTION

**AUTOMATIC CUT-OUT.** To help ensure your Booster's motor long life and to prevent damage, it is fitted with automatic thermal overload protection. This switches off the motor if it overheats. If this occurs, switch off the power at the mains supply to the motor. Check for the cause. Usually it will be due to no water flow through the Booster. Check that the pond pump is running correctly and water is flowing through your filter system. Wait 15 minutes for the motor to cool down and automatically reset. Then switch on the mains supply to the motor. If the problem persists, there is a problem

with the motor and should be investigated following the same sequence as if the blue filter valve is staying down.

The valves on the inlet assembly can be used to help determine the problem. The filter bypass valve is red, and in normal operation the valve is fully down, and can not be seen through the clear cap. The pressure sensitive relief valve is blue, and in normal operation should still be high enough to be seen through the translucent blue cap (Fig 24).

**Note: The two caps are different in design and must be replaced with the identical part i.e. blue cap to blue valve and clear cap to red valve. The caps use a bayonet lock system. To remove a cap use the spanner provided ('A' Fig 1). Turn the cap approximately 20° anti-clockwise, lift up slightly, and then turn clockwise to remove (Fig 23).**

#### Possible Problems:

If the blue Filter valve stays fully down (permanently), and very little waste is being flushed out, it is likely that the backwashing has become ineffective and the mesh filter has become blocked:

- Check the power supply to the Saturn Booster. If this is OK:
- Turn off the pond pump and the power supply (to the Saturn Booster)
- Firstly, check that the blue valve is clear of debris by removing the blue cap. If debris is holding the valve open, remove it and re-test for correct operation. If there is still a problem carry out the following checks.
- Remove the Saturn Booster's lid by undoing the eight bolts with the Allen key supplied (Fig 12).
- Turn on the Booster power supply. Water should flow from both ends of the cream rotor causing the rotor to rotate.
- If there isn't any water flowing out of the ends of the rotor, the backwashing pump is defective and needs replacing (see 'Replacing Pump').
- If water is flowing out of the ends of the rotor but the rotor isn't rotating, the rotor may have become partially blocked and will need to be stripped down to clear the blockage (see 'Unblocking Rotor').
- If everything appears in order, then clean the parts using a garden hose to remove any debris and reassemble.

If the red valve is up and water flows back into the pond through the filter bypass hose, **AND** if the blue valve is in it's normal running position (up), it is likely that there is a flow restriction downstream of the Saturn Booster:

- Check that the outlet hose between the Saturn Booster and your filter system is free from obstruction, and that the outlet hose does not rise more than 1m.
- If your filter system is sealed (i.e. water does not return to the pond using gravity), check and clean your filter system.
- If none of these are the problem, then it is possible that some debris may be trapped on the valve seat. To remove the debris, remove the clear cap with the spanner provided (Fig 23), and lift out the red valve assembly. Remove any debris, check the valve foam seal for damage, and re-assemble.

If the flush away hose continues to dribble water after flushing, raise and lower the flush-away handle a couple of times to dislodge any debris that may have prevented the valve from fully closing.

## 3. REPAIR

### Replacing Pump

- Turn off the pond pump and isolate the power to the Saturn Booster.
- Disconnect the Saturn Booster's cable from the power supply.
- Pull the flush-away handle up to lower the water level in the Saturn Booster.
- If necessary, disconnect the two hoses connected to the inlet assembly.
- Remove the Saturn Booster lid by undoing the 8 bolts with the Allen key supplied and place to one side (Fig 12)
- Gently lift the cream moulding up and out of the vessel (Fig 13). This will bring the complete backwash assembly (including the motor) out of the vessel.
- Invert the backwash assembly on top of the vessel - there is sufficient slack in the pump power supply cable to do this (fig 14).

At this point it is advisable to prepare for routing the power cable of the new pump. The easiest way to do this is to attach some string to the free end of the original power cable, this can then be used to pull the new power cable through the cable gland to the outside of the Booster:

- Loosen the cable gland where the power cable enters the vessel (fig 15).
- Attach about 2m of string to one of the inner conductors of the free end of the power cable.
- Gently pull the power cable into the Saturn Booster until the string is accessible from both inside and outside. This will be used to pull through the cable routing replacement pump power cable (Fig 16)
- Remove the string from the power cable.
- Undo the single central bolt (Fig 17) and gently lift off the black pump moulding.
- Unscrew the four screws holding the motor in place (Fig 18) and gently lift the pump and cable clear.
- Screw the replacement pump in using the same four screws.
- Attach the string to the new power cable and gently pull all the way through until you have about 200mm slack (to allow the backwash assembly to be turned the correct way around for reassembly).

Re-assembly is the reverse of dismantling, but note:

- Ensure the Backwash Assembly is located correctly (Fig 19).
- Using a 19mm spanner, tighten the nut on the cable gland (Fig 15), and remember to check it for leaks after re-starting.
- Ensure the main seal is securely located on the lid. It is slightly smaller than the lid to ensure it stays in place when the lid is inverted for assembly.
- Replace the lid carefully ensuring the lid seal is securely in place. Tighten all the lid bolts using the Allen key provided (Fig 20).

When restarting the Booster, follow the

instructions and check for leaks.

#### Unblocking the Rotor:

- Turn off the pond pump and isolate the power to the Saturn Booster.
- Disconnect the Saturn Booster cable from the power supply.
- Pull the flush-away handle up to lower the water level in the Saturn Booster.
- If necessary, disconnect the two hoses connected to the inlet assembly.

Remove the Saturn Booster lid by undoing the 8 bolts with the Allen key supplied and place to one side (Fig 12). Hold the cream moulding and carefully lift out the backwash assembly (Fig 13). Place the backwash assembly unit upright on the ground. Undo the central bolt holding the top of the backwash assembly using the Allen key supplied. (Fig 21). The cream rotor may now be lifted up and removed (Fig 22). Inspect the rotor for signs of blockage. If the blockage cannot be cleared by flushing the rotor with a garden hose, it will need to be dismantled by undoing 8 screws. When dismantled, clean the inside of the rotor. Re-assembly is done in the reverse order to dismantling, but note: Before replacing the rotor, check for debris on the upper white and the lower black bearing and clean if required.

- The black rubber seal on the top of the mesh filter and the seal on top of the inner vessel may have lifted off with the cream moulding. If so, remove the two seals from the cream moulding and replace on the mesh filter and inner vessel before re-assembling.
- Replace the lid carefully ensuring the lid seal is securely in place. Tighten all the lid bolts using the Allen key provided (Fig 20).

## SPARE PARTS

Contact Hozelock Cyprio, Customer Services Department.

Item Numbers	
1. Backwashing pump	Z12795
2. Gauze drum	Z12799
3. Inlet manifold	Z12770
4. Outlet manifold	Z12780
5. Self regulating valve	Z12760
6. System relief valve	Z12750

## 2 YEAR GUARANTEE

If this product becomes unserviceable within 2 years of the date of purchase it will be repaired or replaced at the agent's option - free of charge unless in the agent's opinion it has been damaged or misused. To obtain the benefits of this guarantee send the product along with proof of purchase direct to Hozelock Cyprio, Customer Services Department.

**Hozelock Cyprio**  
Midpoint Park  
Birmingham  
B76 1AB  
England  
Tel: 0870 850 1959  
www.hozelock.co

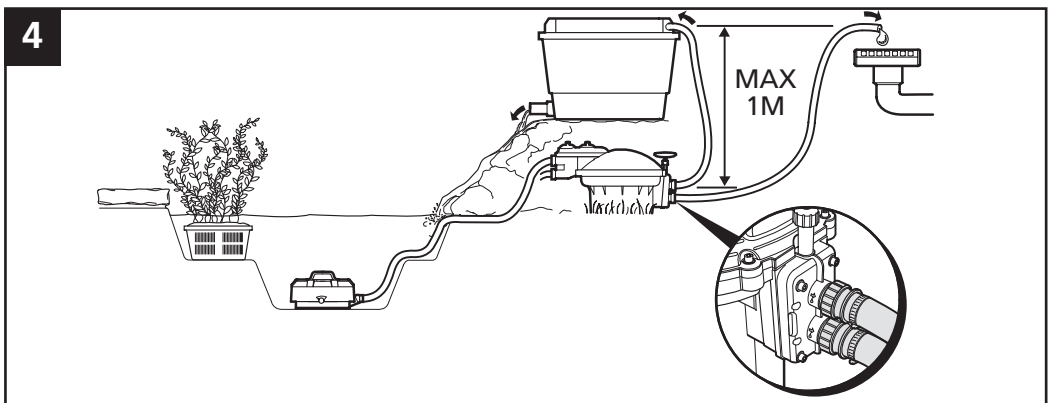
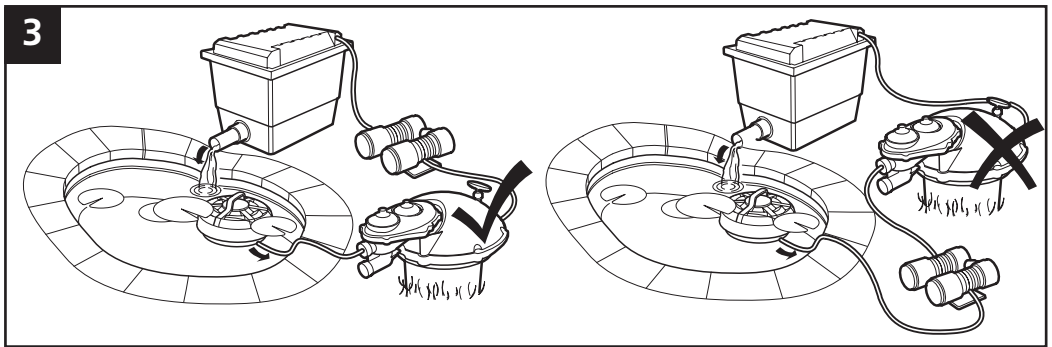
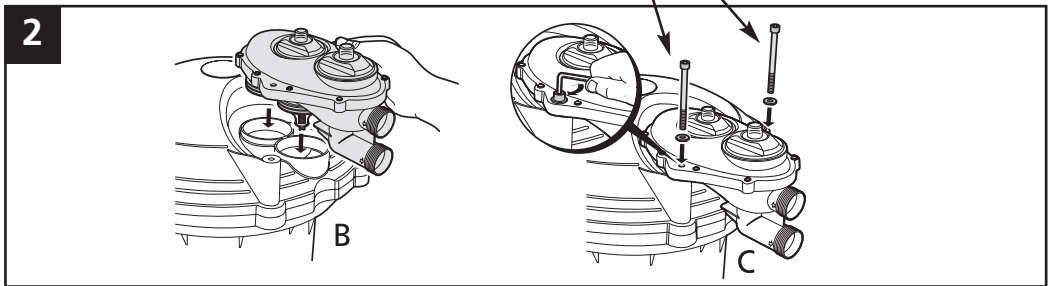
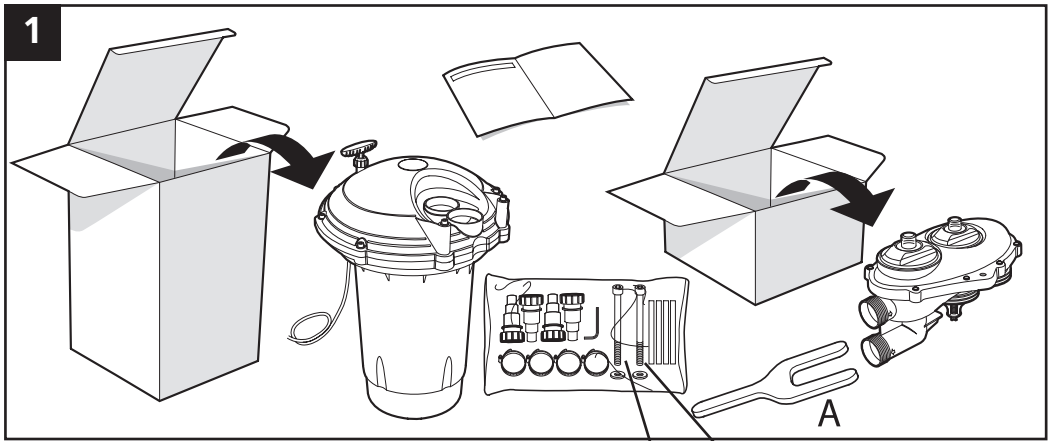

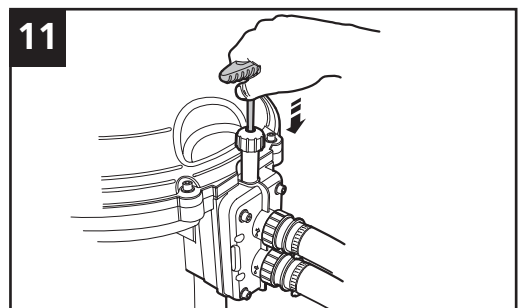
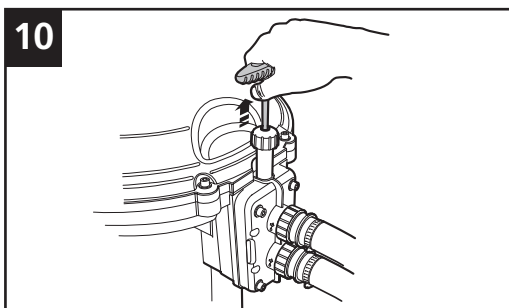
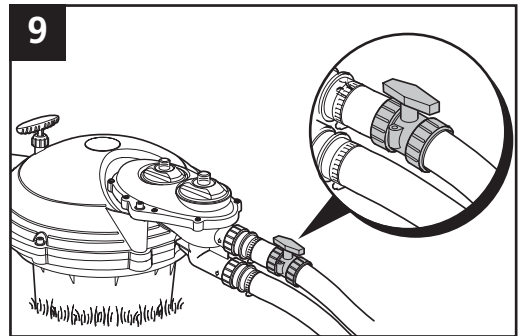
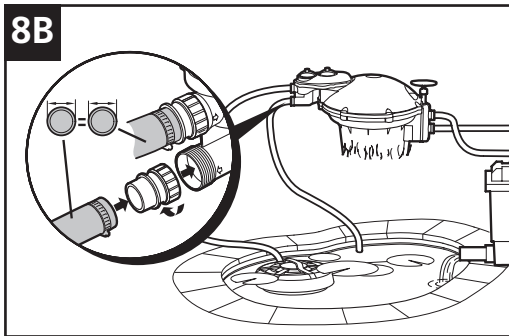
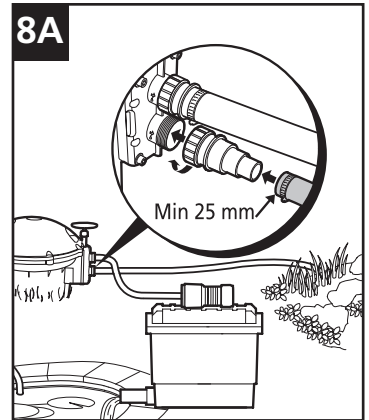
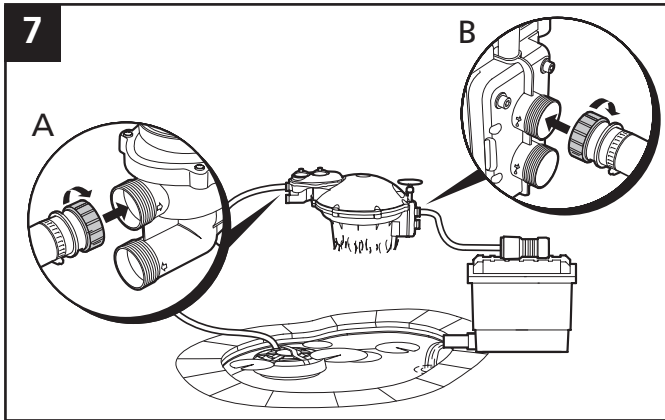
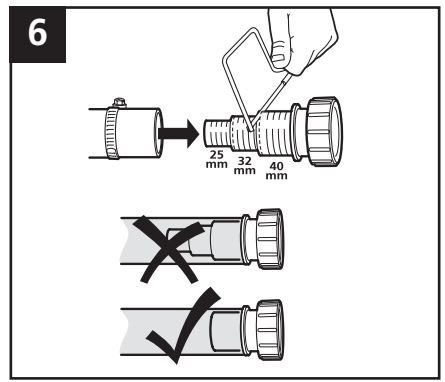
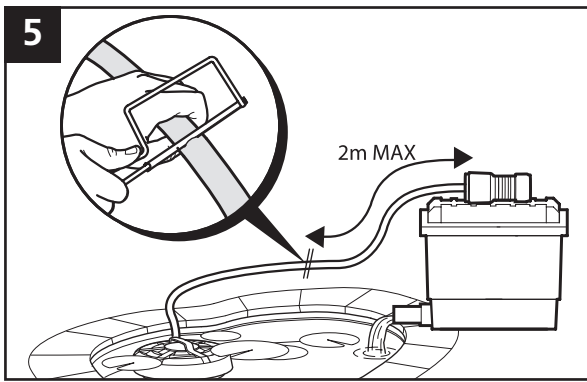

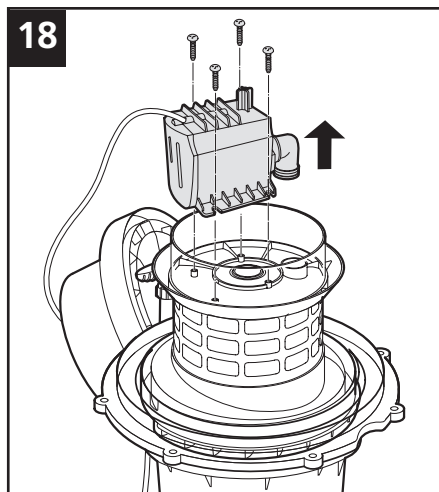
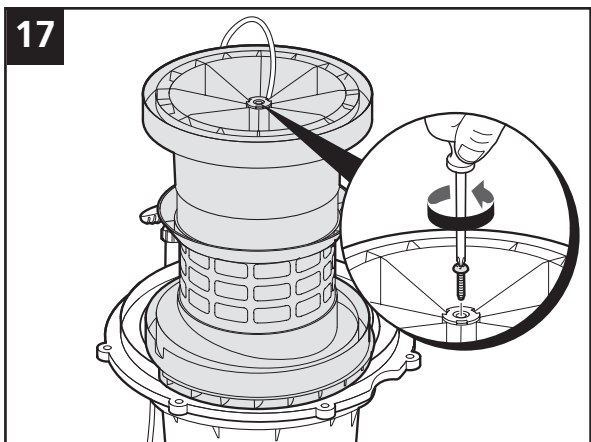
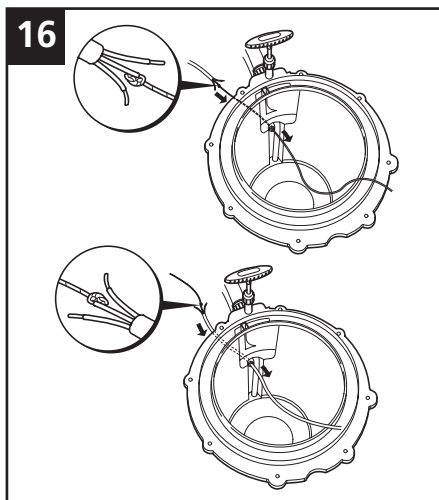
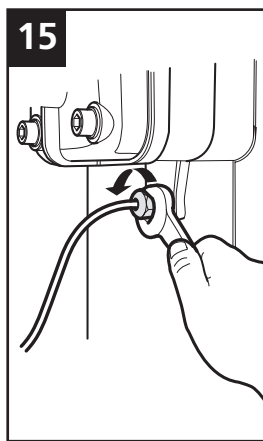
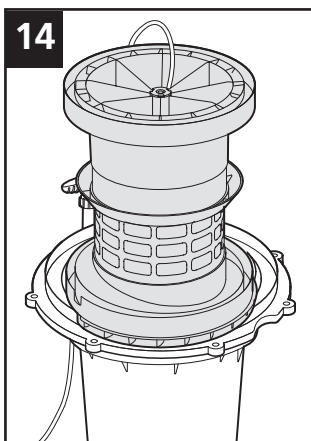
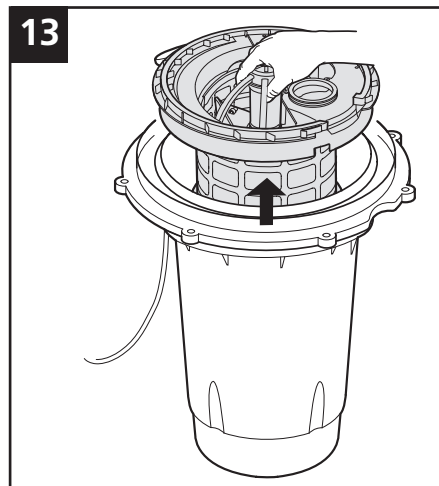
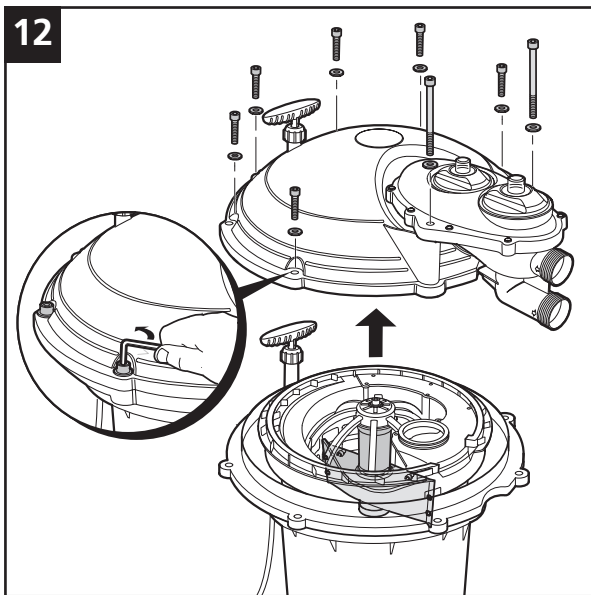

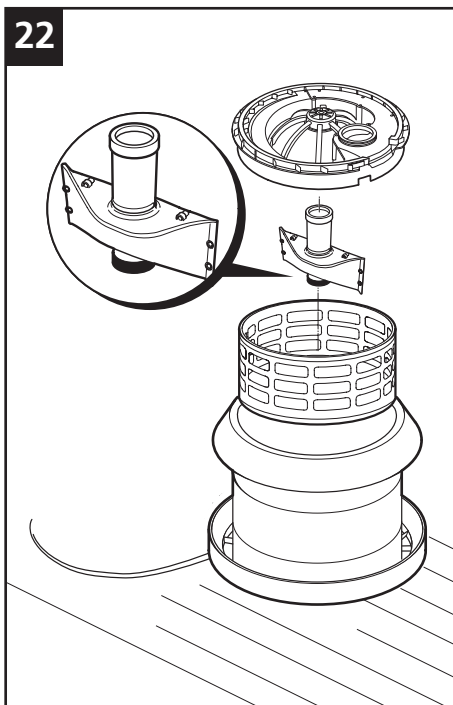
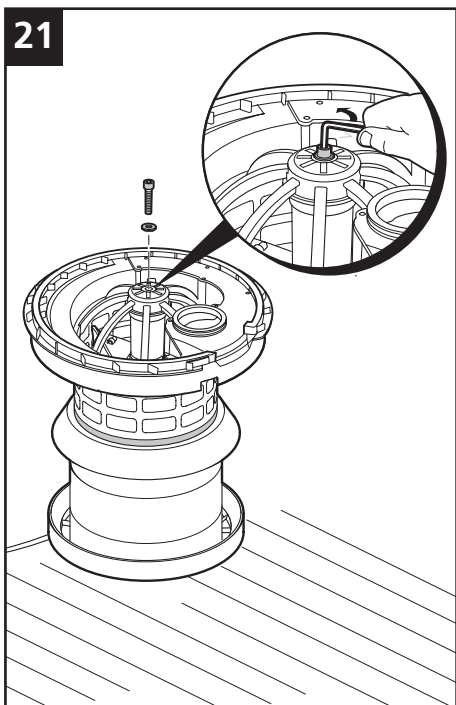
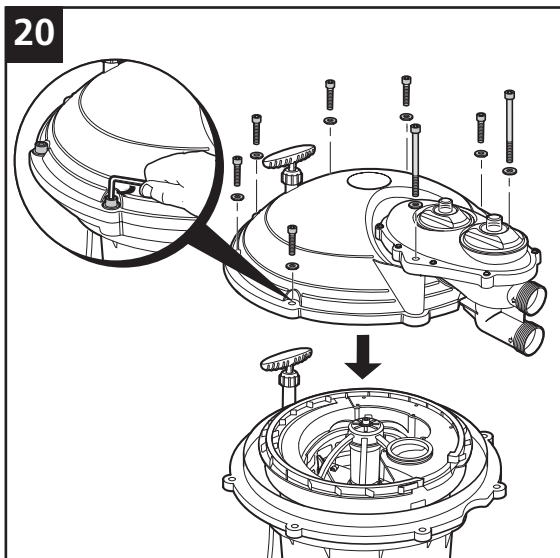
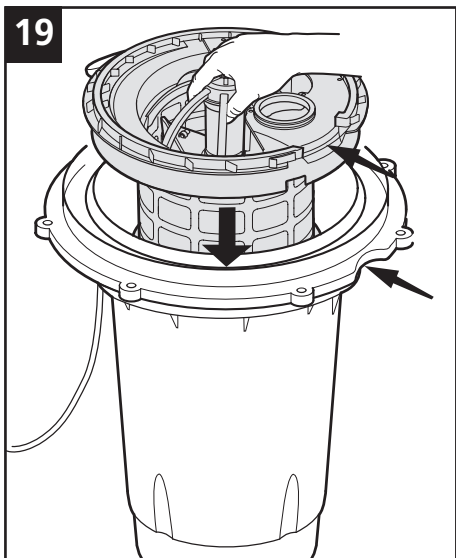

23

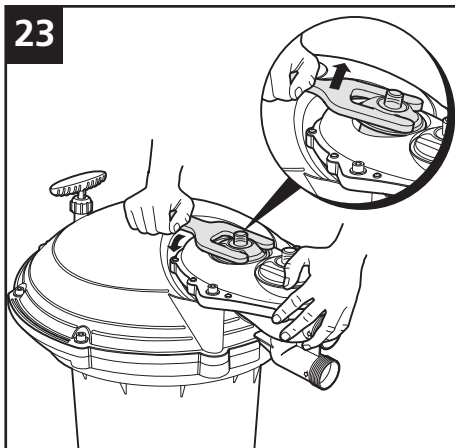

24

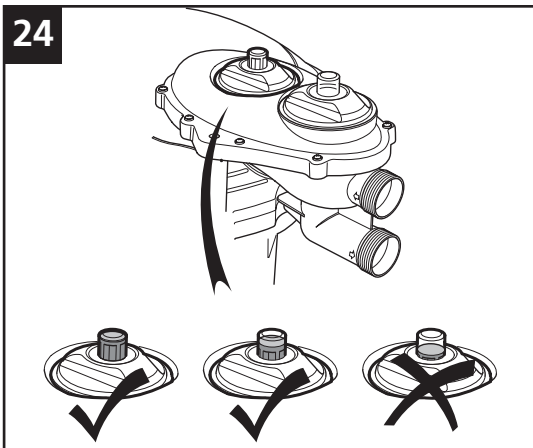

**Hozelock Cyprio**  
Midpoint Park, Birmingham, B76 1AB  
England.  
Tel: +44 (0) 870 850 1959 Fax: +44 (0) 121 351 2176  
[www.hozelock.com](http://www.hozelock.com)  
The Aquatics Division of Hozelock Group

33448-001

