

3324

3334

3344



Cascade 2000, 3000 & 4000

INSTALLATION AND OPERATING INSTRUCTIONS. READ INSTRUCTIONS CAREFULLY BEFORE ATTEMPTING INSTALLATION.
KEEP THESE INSTRUCTIONS FOR FUTURE REFERENCE

ATTENTION

AUTOMATIC CUT-OUT. To help ensure your pump's long life and to prevent damage, it is fitted with automatic thermal overload protection. This switches off the pump if it overheats. If this occurs, switch off the power at the mains supply to the pump. Check for the cause. Usually it will be debris blocking the inlets of the pump or obstructing the impeller. Remove the obstruction and wait 15 minutes for the pump to cool down and automatically reset. Then switch on the pump again.

NOTE: YOU MUST SWITCH OFF THE MAINS SUPPLY BEFORE THE PUMP WILL RESET.

From 1st January 2005 installing this product in the garden is classed as 'notifiable' in the revised Building Regulations for England and Wales. The Regulations now require you to tell your local authority building control department that you intend to install this product before installation. Your local authority will let you know how you can get your installation approved.

Cascade 2/3/4000 - H-max 2.3m

The Hozelock Cyprio Cascade 2000, 3000 & 4000 pumps are designed for submersible use only. The pump does not use oil or grease for lubrication and can be used safely in ponds containing fish or plants. The motor consists of a sealed stator and water-cooled permanent magnet rotor. All electrical components are isolated from the water.

IMPORTANT

- WARNING: ALWAYS UNPLUG OR DISCONNECT ALL APPLIANCES IN THE POND FROM THE ELECTRICITY SUPPLY BEFORE PUTTING YOUR HANDS IN THE WATER WHILST EQUIPMENT IS BEING INSTALLED, REPAIRED, MAINTAINED OR HANDLED.**
- Do not use the supply cable to lift the pump, as this may cause damage. We recommend fitting a lifting cord to the handle eye on the top of the strainer cage when the pump is installed in deep water.
- Do not operate or leave the pump in freezing conditions.
- Do not allow the pump to run dry.
- Check that the voltage marked on the pump corresponds to the mains supply.
- A 10MA OR 30 MA RESIDUAL CURRENT DEVICE **MUST BE FITTED TO THE MAINS SUPPLY.**
- DO NOT OPERATE THIS PUMP WITHOUT THE STRAINER CAGE ATTACHED. USING THE PUMP WITHOUT A STRAINER CAGE MAY INVALIDATE YOUR WARRANTY.**

WARNING: SAFETY AND ELECTRICAL CONNECTIONS

- The pump is supplied with 10m of 3 core electric cable which is permanently connected and sealed to the motor. The supply cable cannot be replaced. If the cable is damaged, the pump should be discarded. This product is designed to be

permanently wired to the mains supply in a dry weatherproof enclosure through a Double-Pole Switched Fused Spur - (Disconnector) to BS 3676, with a minimum contact separation of 3mm in each Pole - Fitted with a 3 or 5 Amp fuse.

The installation must conform to the national and local wiring regulations which could include the use of plastic or metal conduit to protect the cable.

- A 10MA OR 30MA RESIDUAL CURRENT DEVICE (RCD) **MUST BE FITTED TO THE MAINS SUPPLY.**
- WARNING: THIS APPLIANCE MUST BE EARTHED AND IT IS ESSENTIAL THAT THE CONNECTIONS ARE MADE USING THE FOLLOWING CODE;**



The BROWN lead should be connected to the LIVE terminal which may be marked with an 'L' or coloured brown or red.

The BLUE lead should be connected to the NEUTRAL terminal which may be marked with an 'N' or coloured blue or black. The GREEN/YELLOW lead should be connected to the EARTH terminal which may be marked with an 'E' or coloured green or green/yellow.

- If an extension cable is required, this should be connected to the end of the pump cable using a weatherproof cable connector. The joint must be positioned in a suitable weatherproof housing. The extension cable should be of 3 core 0.75mm² Polychloroprene rubber insulated cable (ref: HO5 RN-F) and permanently wired to the mains supply with a 3 or 5 Amp fuse.
- The pump cable (and extension cable) should be positioned and adequately protected against damage especially where contact with gardening equipment (lawn mowers, forks etc.) children and domestic animals may occur.
- CONSULT A QUALIFIED ELECTRICIAN OR LOCAL AUTHORITY IF IN ANY DOUBT ABOUT WIRING TO THE MAINS SUPPLY.

ACCESSORY ASSEMBLY

Teep Piece

- Locate the fountain flow adjuster (See Fig1-A) to the tee piece body with the peg positioned downwards to engage in the tee. Push in fully and snap them together.
- Locate the valve stem (B) to the waterfall flow adjuster (C) and snap them together. Screw the valve assembly into the longer boss (D) on the tee piece. See Fig 1.

Telescopic Stem

- Slide the Inner Tube (E) through the Telescopic Stem Nut (F) and "O" ring (G). Push the Inner Tube into the Outer Tube (H) and gently screw down the nut. The finishing position of the tee piece is not important. The maximum to minimum range of the Telescopic stem is 150mm (6") (See fig 2).

Bell Fountain

- Locate the Bell Support (I) to the Bell Main

- Body (J) and push fully home.
- Position the Bell (K) to the Body Assembly and press into the central location. See fig 3.

PUMP INSTALLATION

ATTENTION: This product is not suitable for water temperatures above 35°C

Position

Construct a solid and level platform on which to place the pump. For installations using the fountain tops directly on the Tee Piece, the top level of the platform should be 300 mm (12") below the water level. For installations using the fountain tops directly on the Tee Piece and Telescopic Stem, the top level of the platform should be 450 mm (18") below the water level.

Fountain Only. (See Fig 7 for general installation guide)

- Place the pump next to the pond and route the cable back to the mains supply.
- Position the pump with the Tee Piece Assembly and if required the Telescopic Stem with the fountain fitted in the desired position in the pond. The 2 and 3 tier fountain heads simply snap onto the fountain stem (See Fig 4).
- The fountain height can be regulated to suit your needs by rotating the Fountain Flow Adjuster. See Fig 5 (L).
- If required, the 2-Tier Fountain head, Fig 5 (M), can be used to achieve an alternative and higher display pattern than the 3-Tier, Fig 5 (N).
- The Bell Fountain creates a decorative waterbell. The size of the bell can be regulated by adjusting the flow through the Tee Piece by rotating the fountain flow adjuster and/or by raising or lowering the top of the Bell in main Bell Body.
- The ball joint on the bottom of the tee Piece, Fig 5(O) can be used to adjust the fountain angle so that it is vertical.

Fountain and Waterfall. (See Fig 8 for general installation guide)

- Position the pump as previously described.
- Attach a suitable length of 25 mm (1") hose to the Threaded Hose tail, Fig 5 (P), and secure with a suitable hose clip and position the outlet end of the hose in the desired position.
- Screw the Threaded Hose tail onto the waterfall outlet side of the Tee Piece.
- The combination of waterfall and fountain will reduce the fountain height that can be achieved.
- Once the pump is operating the flow of the waterfall and the height of the fountain can be independently adjusted.

Waterfall Only. (See Fig 9 for general installation guide)

- Position the pump as previously described.
- Attach a suitable length of 25 mm (1") hose to the Threaded Hose tail and secure with a suitable hose clip and position the outlet end of the hose in the desired position.
- For maximum waterfall flow, screw the Threaded Hose tail directly onto the outlet of the pump. Some installations require

the flow of the water to be adjusted. In these cases, screw the Tee Piece to the outlet of the pump, screw the Threaded Hose tail to the water fall outlet boss and adjust the flow using the waterfall flow adjuster, Fig 5 (Q), to suit your needs.

MAINTENANCE

The Hozelock Cyprio range of Cascade pumps has been designed to allow fast and easy maintenance. As with all pumps of its kind, occasionally it will become necessary to clean the Strainer Cage and Fountain Spray head ring.

ALWAYS UNPLUG OR DISCONNECT ALL APPLIANCES IN THE POND FROM THE ELECTRICITY SUPPLY BEFORE PUTTING YOUR HANDS IN THE WATER OR STARTING MAINTENANCE.

Fountain Head

1. Place a coin or similar in the slot and gently lever off the fountain head.
2. Rinse in clean water and reassemble.

Strainer

1. Remove the accessories from the pump outlet.
2. Holding the pump in one hand, press the release button on the top of the pump and open Strainer Cage. See Fig 5 (R).
3. Slide the pump out of its location and wash/rinse the Strainer Cage with clean water. The hinges on the Strainer Cage should also be washed clean at this time.
4. Reassemble the pump.

Rotor Assembly

1. Remove the Strainer Cage as described above.
2. Release the Pump Chamber, Fig 6 (S), by rotating it until the

two retaining tongues are clear of the lugs on the Motor Body.

3. Gently pull the Pump Chamber squarely away from the Motor Body.
4. Pull the Rotor Assembly out of the Motor Body. See Fig 6 (T).
5. Wash out all of the components in clean water. Do not use detergents or other chemical cleaners.
6. Replace the Rotor Assembly into the Motor Body and refit the Pump Chamber and Strainer Cage.

ALL YEAR PUMP CARE

A quick daily check should be carried out to ensure that the pump is performing satisfactorily.

Once a week- Remove and clean the Strainer Cage and Fountain Head in accordance with the general maintenance notes. Depending on pond water conditions, cleaning may be required more frequently.

Once a year- Completely disassemble the pump including the Rotor Assembly as described in the general maintenance notes and wash all components in clean, fresh water. Replace worn or broken parts.

SPARE PARTS

Contact the Consumer Services Helpline on 0870 850 1959

HOZELOCK CYPRIO 3 YEAR GUARANTEE

If this pump, excluding the Rotor Assembly, becomes unserviceable within 3 years of the date of purchase it will be repaired or replaced at our option free of charge, unless in our opinion it has been damaged or misused.

Liability is not accepted for damage due to accident, improper installation or use. Liability is limited to replacement of a faulty pump. This guarantee is not transferable. It does not affect your statutory rights.

To obtain the benefits of the guarantee,

firstly contact Hozelock Cyprio Consumer Services who may request that the pump is sent along with proof of purchase directly to the address below.

DAMAGE CAUSED BY RUNNING THE PUMP DRY OR BY FROST INVALIDATES THE GUARANTEE.

Item Numbers	
	2000
Pump Chamber and Seal.	Z13245
Rotor Assembly.	3408
Strainer Cage.	Z13215
Fountain Kit.	3403
	3000
Pump Chamber and Seal.	Z13255
Rotor Assembly.	3408
Strainer Cage.	Z13215
Fountain Kit.	3403
	4000
Pump Chamber and Seal.	Z13255
Rotor Assembly.	3411
Strainer Cage.	Z13215
Fountain Kit.	3403

FAULT FINDING

WARNING: ALWAYS UNPLUG OR DISCONNECT ALL APPLIANCES IN THE POND FROM THE ELECTRICITY SUPPLY BEFORE PUTTING YOUR HANDS IN THE WATER WHILST EQUIPMENT IS BEING INSTALLED, REPAIRED, MAINTAINED OR HANDED.

IMPORTANT - PLEASE KEEP THIS SECTION FOR REFERENCE

LOW FLOW FROM PUMP

1. Ensure the Strainer Cage is clean.
2. A small diameter outlet pipe will restrict outlet flow.
3. Clear any blockages and adjust the flow controls.

NO FLOW FROM PUMP

1. Check power supply is on.
2. Check fuse and wiring.
3. Check the Rotor Assembly is not jammed, damaged or showing signs of excessive wear.
4. Ensure the Strainer Cage is clean.

POOR FOUNTAIN DISPLAY.

1. Clean the Fountain Head. (see maintenance).

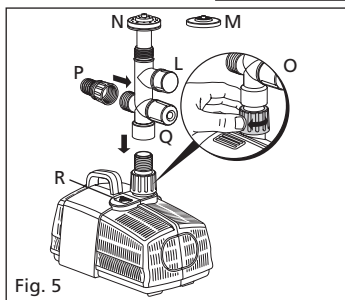
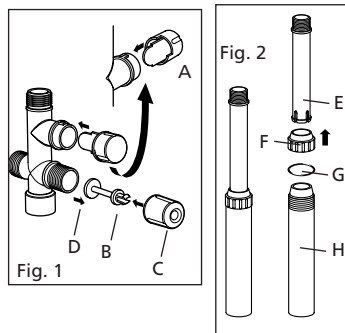

Hozelock Cyprio
Midpoint Park, Birmingham B76 1AB
Telephone: +44(0) 870 850 1959
www.hozelock.com

The Aquatics Division of Hozelock Group

33633-001

